

ASSA ABLOY Automatic doors

ASSA ABLOY
Entrance Systems

Doors for businesses
that never compromise

assaabloyentrance.com/in

Experience a safer
and more open world



We never compromise with your automatic door system

Proven expertise

From the start of our journey all the way through to our current set-up as ASSA ABLOY, our automatic door systems have consistently led the industry when it comes to quality, reliability, and convenience. Everything we produce is designed by our global team of expert technicians and engineers, each of whom shares a passion for sustainable innovation.



Robust and high quality

We've spent 50+ years improving and perfecting our automatic entrance systems. Combining highly robust materials with state-of-the-art technology designed to ensure safe and seamless user flow – while enabling us to maintain a solid legacy.

Safe and secure technology

Our systems come equipped with the latest safety features, enabling comfortable and secure passage at all times and under any circumstance. Should an obstruction be detected, our operators will immediately pull doors open and then resume interrupted movement at low speed to ensure the obstruction is no longer there.



Full solution and service partner

As a full service provider we offer businesses total freedom to customize their sliding door systems, with a variety of frames, glass panels and colors to choose from. We also offer tailored maintenance and service agreements, with our service experts available to solve issues whenever you need them.



Ultimate reliability designed for your needs

Automatic sliding doors allow for the smooth and safe passage of people and goods all day, every day. That's why the right entrance solution can – and should – be a lifeline for any business or establishment looking to keep visitors and staff secure at all times.

Understanding businesses and buildings

As a global leader in automatic entrance systems, we understand businesses and buildings and how to meet the needs of our customers and end users whatever the environment:

In high-traffic areas such as airports or public transport hubs, our systems are designed to withstand constant use from pedestrians and heavy items such as trolleys. In healthcare settings where proper hygiene is vital, our systems can be used to create tight-sealing sliding door systems capable of maintaining optimal health and safety standards. And at establishments where passageways should be safe and stylish – like hotels – our high-quality offerings deliver on both fronts.

We are constantly challenging the accepted. Always improving our technology to redefine entrance systems and optimize their overall performance, safety, reliability and environmental impact.

At ASSA ABLOY we know for our customers,
their doorway is their connection to the world.
And that's something we can never compromise.

Our automatic sliding door portfolio

When you buy a solution from ASSA ABLOY Entrance Systems, you'll get more than just a physical product. You'll also get the dedication, experience and expertise of our world-class technicians and engineers. A team dedicated to paying attention to every little detail.

SL300

The ASSA ABLOY SL300 is designed to meet the essential performance requirements of any high-quality operator.

SL500

The ASSA ABLOY SL500 is the most advanced sliding door operator that always delivers exceptional performance – without compromising on safety or security.

Sliding door solutions for*



Single

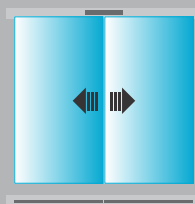

Double

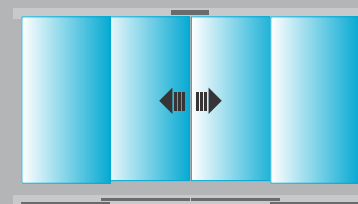

Bi-part

*These models represent only a handful of our solutions. For the full range please contact your local sales office or visit our website: assaabloyentrance.com/in

	SL300	SL500
Performance Performance level to meet the high-flow of pedestrians	Essential performance	Exceptional performance
Safety and security Keeping staff and end-users safe and secure	✓*	✓
Reduction of energy cost Reducing cost through lower energy consumption	✓	✓
Indoor climate control Improved indoor climate for healthier work and business environment	✓	✓
Unexpected breakdowns On-site repairment of unexpected breakdowns among other daily activities	✓	✓
Access to data Access to user flow data for more business insights		✓
Customization Customizable according to business requirements and daily traffic flow		✓

Features



Performance

Performance level to meet the high-flow of pedestrians



Safety and security

Keeping staff and end-users safe and secure



Reduction of energy cost

Reducing cost through lower energy consumption



Indoor climate control

Improved indoor climate for healthier work and business environment



Unexpected breakdowns

On-site repairment of unexpected breakdowns among other daily activities



Access to data

Access to user flow data for more business insights



Customization

Customizable according to business requirements and daily traffic flow

*Without break-out function

SL300

Reliable for your business.
Good for the planet.
Safe for people.



ASSA ABLOY SL300

Essential performance
from a highly reliable
sliding door system

ASSA ABLOY SL300 is designed to meet the essential performance requirements of any high-quality sliding door system.

Affordable quality

Made from only the finest and most robust materials, the SL300 can help you create the ideal automatic sliding door system – whether it concerns an existing location, redesign or entirely new build.

This highly flexible offering can also be fitted with extra sensors to further fine-tune opening and closing times and reduce fluctuations in temperature, for an overall healthier indoor environment.

Furthermore, the SL300 is available in an assembly kit for easy on-site installation.



Specifications

Max. door weight [kg] (1-leaf/2-leaf)	1x120 / 2x100
Max. opening width [mm] (1-leaf/2-leaf)	2,000
Drive dimensions (HxD)	108 x 145
Performance level	Essential
High customization	N / A



Certifications

EU machinery directive / EU safety (CE mark) | ✓ / PLC

Sliding Door Operator

ASSA ABLOY SL300



ASSA ABLOY SL300 sliding door can offer an attractive automatic entrance for you with a small installation space, convenient for design and construction. It is an ideal choice when choosing one of our automatic door products

Never compromise

The SL300 is a high-quality sliding door tailored to meet the essential needs of an automatic sliding door while providing an attractive open entrance with flexible features that make installation convenient and the ideal automatic door for existing locations, redesigns and new constructions. Developed by our team of leading engineers, the door delivers the same durability and long-lasting operation that ASSA ABLOY customers can rely on.

Proven quality

With more than 50 years of experience across the globe, ASSA ABLOY Entrance Systems is the industry leader in the development, production and service of automatic doors. Headquartered in Switzerland, our high-quality products have obtained the LRQA ISO 9001 certificate and obtained the US UL safety certificate, Germany's TUV certificate, Sweden's RISE safety certificate, Sweden's SITAC certificate, the CE certificate test standard, and the Chinese National Research Centre of Testing Techniques for Building Materials.

Technical specifications

Power supply	100 - 240V AC \pm 10% ; 50/60 Hz
Power consumption	max. 200 W
Recommended max. door weight	
ASSA ABLOY SL300-2	max. 100 kg/door leaf
ASSA ABLOY SL300-R/L	max. 120 kg
Clear opening width (COW)	
ASSA ABLOY SL300-2	1100-2000 mm
ASSA ABLOY SL300-R/L	900-2000 mm
Hold-open time	0 – 60 s
Ambient temperature	-20°C to +50°C
Relative humidity (non-condensing)	max. 85%

Guaranteed performance & safety features

The SL300 keeps people flow smooth and customers safe. To ensure risk-free passage between closing doors, the SL300 reverses its doors if an obstruction is detected, then resumes the interrupted movement at low speed to ensure the obstruction is no longer there. If an obstruction is detected during opening, the doors stop immediately and close after a time delay.

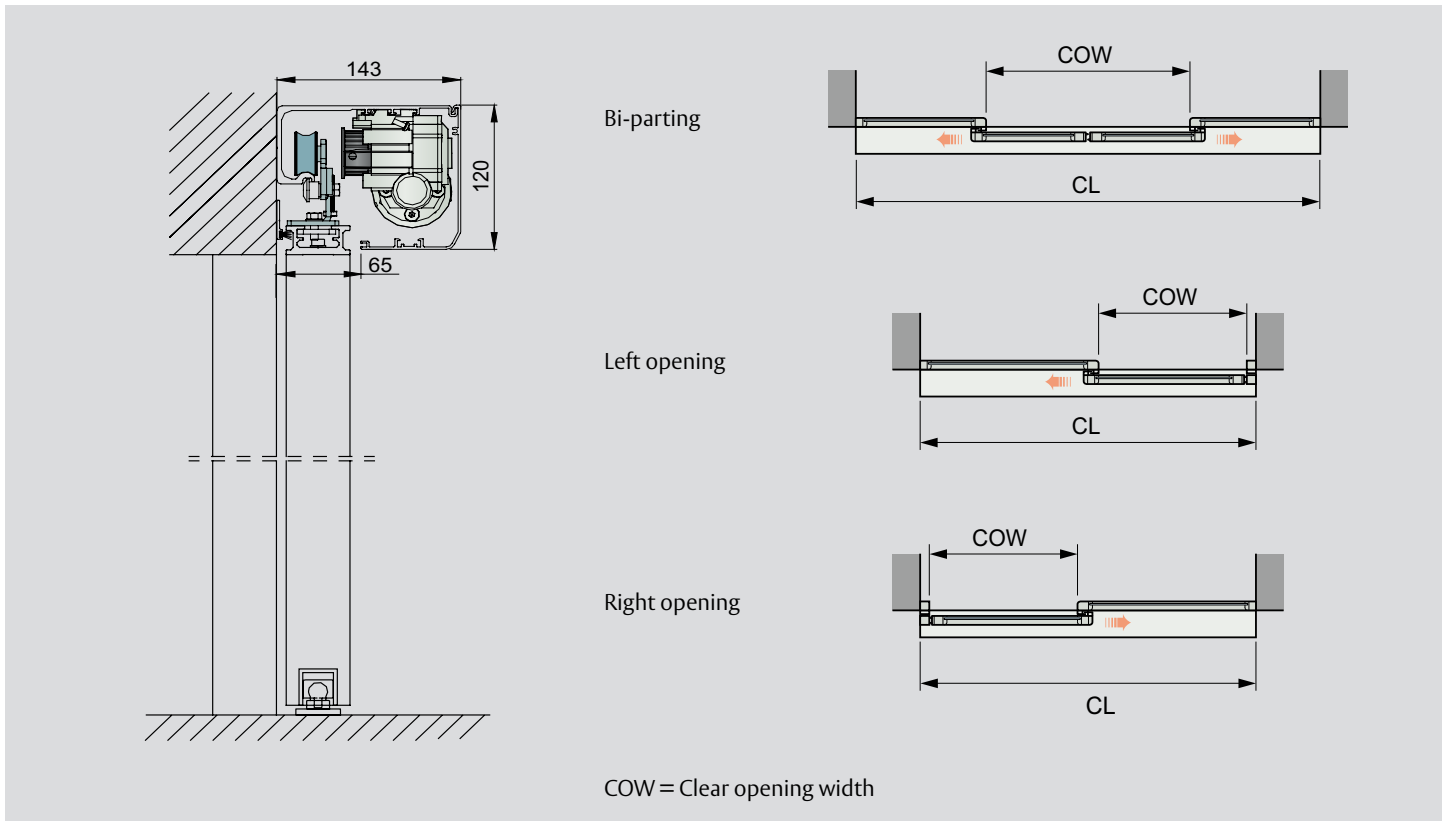

The speed and force of the doors can be customized to optimize safety for any business' needs. And to maximize safe operations and foot traffic, an optional monitored ASSA ABLOY presence detection system can be easily integrated with the SL300.

An option for any need

The SL300 is available in a range of different solutions to offer you high flexibility and convenience:



- An operator only version, optimized in size to fit a wide range of installation sites.
- An assembly kit that allows for easy shipment to you or any end-user and convenient self-assembly on-site.
- A full solution including the operator and frame for the specific usage, easy installation on-site and an ongoing service and maintenance contract with the ASSA ABLOY service solutions.

Customized design & adaptable features

The SL300 has a variety of smart components that make it easy to use, maintain and install. The operator is designed to adapt to a wide range of installation sites, while the control unit is equipped with dual microcontrollers for fast computing and response speed. And the high-performing DC-motor, along with the wheel design, reduces noise and provides a low operating sound level. Furthermore, the module design makes it convenient for easy troubleshooting and keeps maintenance costs minimal.

The ASSA ABLOY SL300 employs the latest software:

- Automatic "Push & Go".
- Double closed-loop monitoring for maximum safety.
- High precision encoder for accurate control.

Standard Equipment
Support Beam
Cover
Drive unit, control unit and components
Sensors for extended safety
Independent certification to EN16005:2012
 

Available in various packages to suit your needs. Packages available:
Amigo
Prime
Elite

Accessories and options
Lock

This equipment should be installed, regularly inspected, maintained and serviced by trained and authorized personnel. Preventive maintenance plans are highly recommended for a proper and safe operation. Talk to your ASSA ABLOY Entrance Systems representative to learn more about our service offering!

SL500

The sliding door for people who never compromise



ASSA ABLOY SL500

Exceptional performance from a high-quality sliding door system

Made from robust and high-quality materials, the customizable SL500 always delivers an exceptional performance – without compromising on safety or security.

High customization

In high-traffic environments such as shopping centers, hotels, transport hubs and hospitals, the SL500 offers a powerful and reliable performance whether your sliding door entrance system has single or bi-part doors. And in businesses where aesthetics are important, we also offer a slimmer, sleeker model.

The ASSA ABLOY SL500 sliding operator is easily adapted for specific performance. The modular composition of the operator facilitates flexibility in every aspect, enabling businesses of all sizes to tailor entrances to meet their unique requirements, without compromising safety, security or energy efficiency. ASSA ABLOY SL500 operator can be integrated as part of our ASSA ABLOY automatic sliding door systems, or be adapted to drive a wide range of pre-existing doors. ASSA ABLOY operators are supplied completely assembled in the appropriate support beam, ensuring quality and ease of installation, whether the operator is part of a brand new system or is supplied as a replacement to an existing installation.

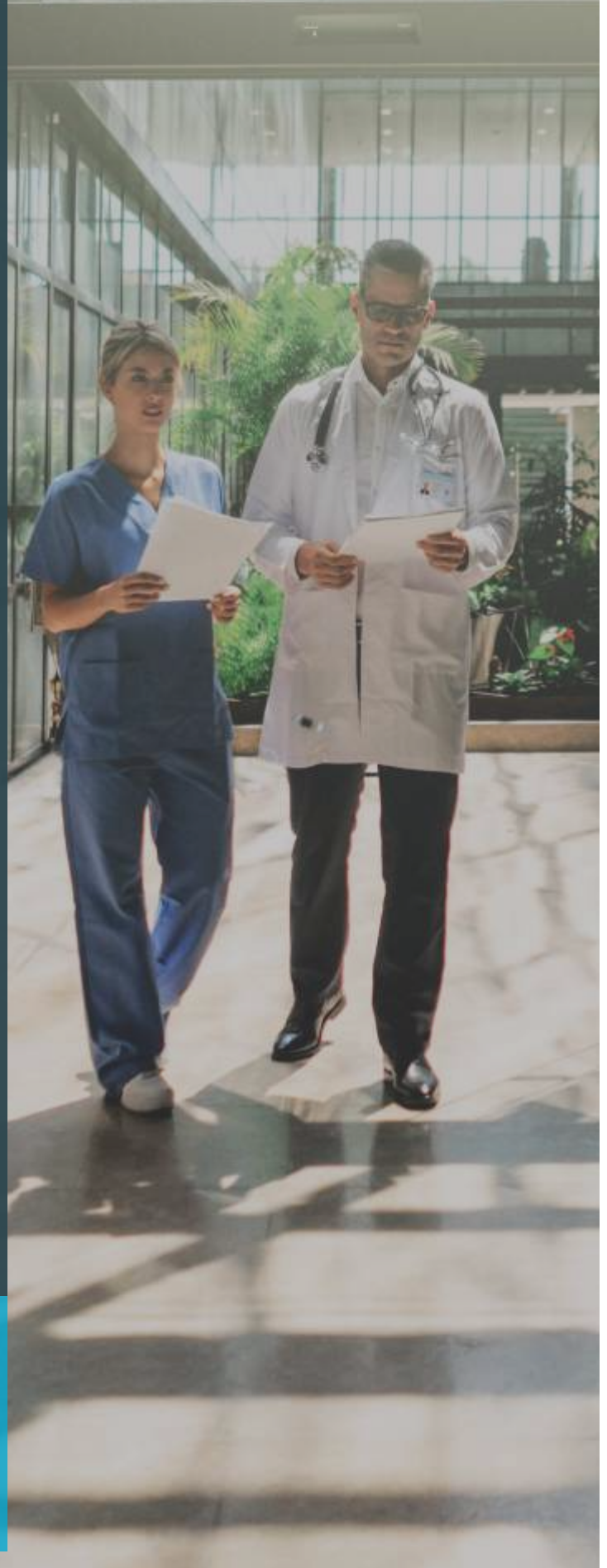



Specifications

Max. door weight [kg] (1-leaf/2-leaf)	1x240 / 2x200
Max. opening width [mm] (1-leaf/2-leaf)	3,000 / 3,000
Drive dimensions (HxD)	150 / 100 x 123 / 198
Performance level	High. except.
High customization	✓



Certifications

EU machinery directive / EU safety (CE mark)	✓ / PLC
--	---------

Sliding Door Operator

ASSA ABLOY SL500



Technical specifications

Operator dimensions	150 mm x 123 mm (height x depth)
Power supply	100-240 VAC ±10% 50/60 Hz
Power consumption	max. 250 W
Recommended maximum door weight	
ASSA ABLOY SL500-2	200 kg/ door leaf
ASSA ABLOY SL500-1	240 kg
Clear opening width (COW)	
ASSA ABLOY SL500-2	1000 – 3000 mm (bi-parting)
ASSA ABLOY SL500-1	900 – 3000 mm (single slide)
Contact local sales representative for other dimensions.	
Open and closing speed variable	up to 1.7 m/s (2 leaves)
Hold-open time	0 – 60 s
Ambient temperature	-20°C to +50°C
Relative humidity (non-condensing)	max. 85%

The modular sliding door ASSA ABLOY SL500 enables upgrades and add-ons when you want to move your business forward

Strong and reliable

In high-traffic retail, transportation and healthcare environments where doors are constantly required to open and close with heavy usage, the ASSA ABLOY SL500 sliding door operator is the reliable choice. Powerful yet smooth operation handles door weights effortlessly; even configurations of 2x200kg or 1x240kg, with the option of configuring entrances in several ways to fit the facility needs.

Safety first

To permit safe passage between closing doors, the doors go into reverse mode if an obstruction is detected, and then start moving again slowly to check if the obstruction has cleared. If an obstruction is detected during opening or between opening doors and surrounding walls or interior fittings, the doors immediately stop and then close after a time delay. The speed and force of the doors can be customized to optimize safety. For optimum safety and user convenience, use a monitored ASSA ABLOY presence-detection system.

Security

Choose your security level by adding different features. Unwanted guests are not an issue for the ASSA ABLOY SL500 through the use of different locking devices. The operation mode selector can be set to meet your security needs during and outside business opening hours. Interlocking facilities further enhance the security level.

Service and maintenance for your convenience

Ensure that you are one step ahead of breakdowns via maintenance indicators and automated diagnostics, or let us handle your maintenance via ASSA ABLOY Entrance Systems' tailored maintenance programs.

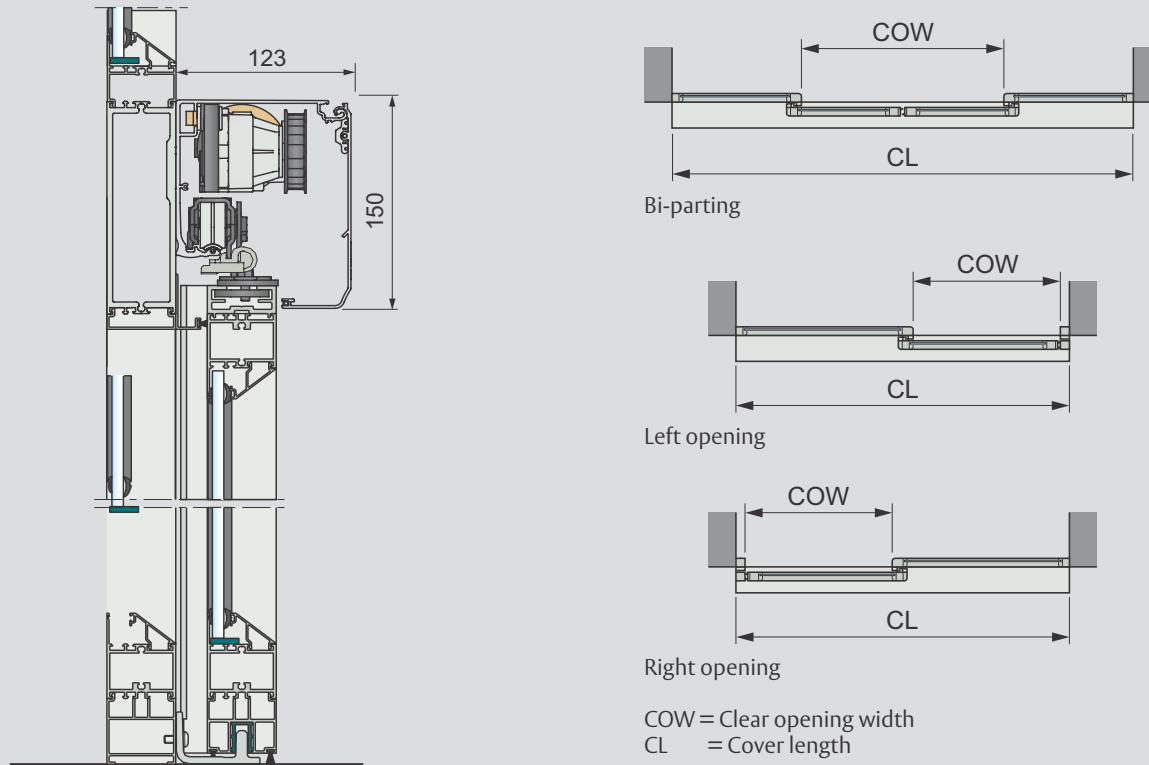

Universal and adaptable

The ASSA ABLOY SL500 series can be tailored to your technical requirements, but also to your budget. Its modular features ensure state-of-the-art versatility and upgrades. Together with our extensive range of different door systems, the operator allows you to create an appealing entrance that perfectly matches your business and traffic flow.

Models

ASSA ABLOY SL500-2 - Two leaves, bi-parting

ASSA ABLOY SL500-R/L - One leaf, single-slide, right or left-opening

Available in various packages to suit your needs. Packages available:

Premium

Paramount

Standard equipment

Cover: clear anodized aluminium

Support beam with transmission

Electronic control unit with plug-in connections and power supply

ASSA ABLOY motion and presence sensors

Key switch

Accessories and options

Door adaptor for doors up to 65 mm thick from other suppliers

Traffic-controlled opening width

Synchronizing of two operators

Operation mode selectors

Electronic emergency opening or closing unit

Emergency button

Electrical locking devices

Interlocking between operators

ASSA ABLOY automatic door systems

This equipment should be installed, regularly inspected, maintained and serviced by trained and authorized personnel. Preventive maintenance plans are highly recommended for a proper and safe operation. Talk to your ASSA ABLOY Entrance Systems representative to learn more about our service offering!



Frames for your entrance system

At ASSA ABLOY, we offer a wide range of frames and door panels to meet the specific requirements of your business needs: whether you're looking for a slim, sleek solution or something more rugged and robust – and able to withstand a high people flow.



Semi-Transparent

All-glass doors featuring sleek metal rails with a virtually uninterrupted glass surface, make your entrance system memorable.



Transparent

Create elegant entrances with a transparent sliding door system. With a virtually uninterrupted glass surface, create an entrance system that will leave an impression.

 Specifications		
U-value on glass	N/A	N/A
Lock (in door system)	Floor lock	N/A
 Combinations		
SL300	✓	✓
SL500 (100/150 height)	✓	✓
 Certifications		
Certified according to EN 160005	✓	✓
Environmental product declaration	N/A	N/A

Automatic sliding door system

ASSA ABLOY Slim

ASSA ABLOY
Entrance Systems

Experience a safer
and more open world



Accessories and Options

Profile type:

- Slim
- Slim Eco

Profile finish:

- anodized aluminium, colour on request

Glass type:

- 8, 10 or 12 mm laminated
- 8, or 10 mm tempered
- 22 mm insulated (Slim Eco profile only)

Glass finish: clear, green, bronze, opaque

Overlight (beam mounted only)

Side screens

Mechanical lock

The ASSA ABLOY Slim series includes:

- ASSA ABLOY Slim
- ASSA ABLOY Slim Eco
- ASSA ABLOY Slim Break-Out
- ASSA ABLOY Slim Reverse Break-Out

ASSA ABLOY Slim & ASSA ABLOY Slim Eco

The system consists of doors with slim line aluminium profiles, operator, safety units and, if required, side screens and overlights. Available for beam- or wall mounting and supplied as bi-parting and single-sliding, all models can be tailored to individual customer requirements, suitable for decorative and functional entrances.

ASSA ABLOY Slim Break-Out & ASSA ABLOY Slim Reverse Break-Out

Break-out enables the doors and side screens to swing outward in an emergency, allowing exit through the entire door and side-screen space.

Reverse break-out performs the same way with the doors swinging inward. Especially suitable for indoor applications.

Safety features

An integrated activation and presence detection system enhances safety for users by detecting people or objects in the doorway, preventing the door from closing until it is safe to do so.

Sustainability

ASSA ABLOY's automatic door systems can reduce the amount of energy needed to heat or cool a building, resulting in lower costs and a smaller carbon footprint for customers. The ASSA ABLOY Slim series can be fitted with optional extra tight-fitting brushes and additional sensors for fine-tuning opening and closing times, further enhancing its energy-saving capabilities. Regular maintenance helps insure top performance and extends the life of the equipment, reducing its impact on the environment.

ASSA ABLOY Slim

ASSA ABLOY SL500

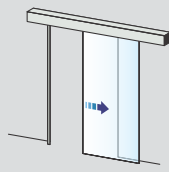
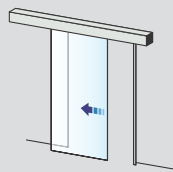
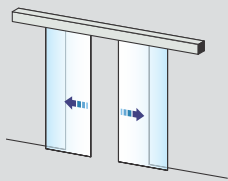
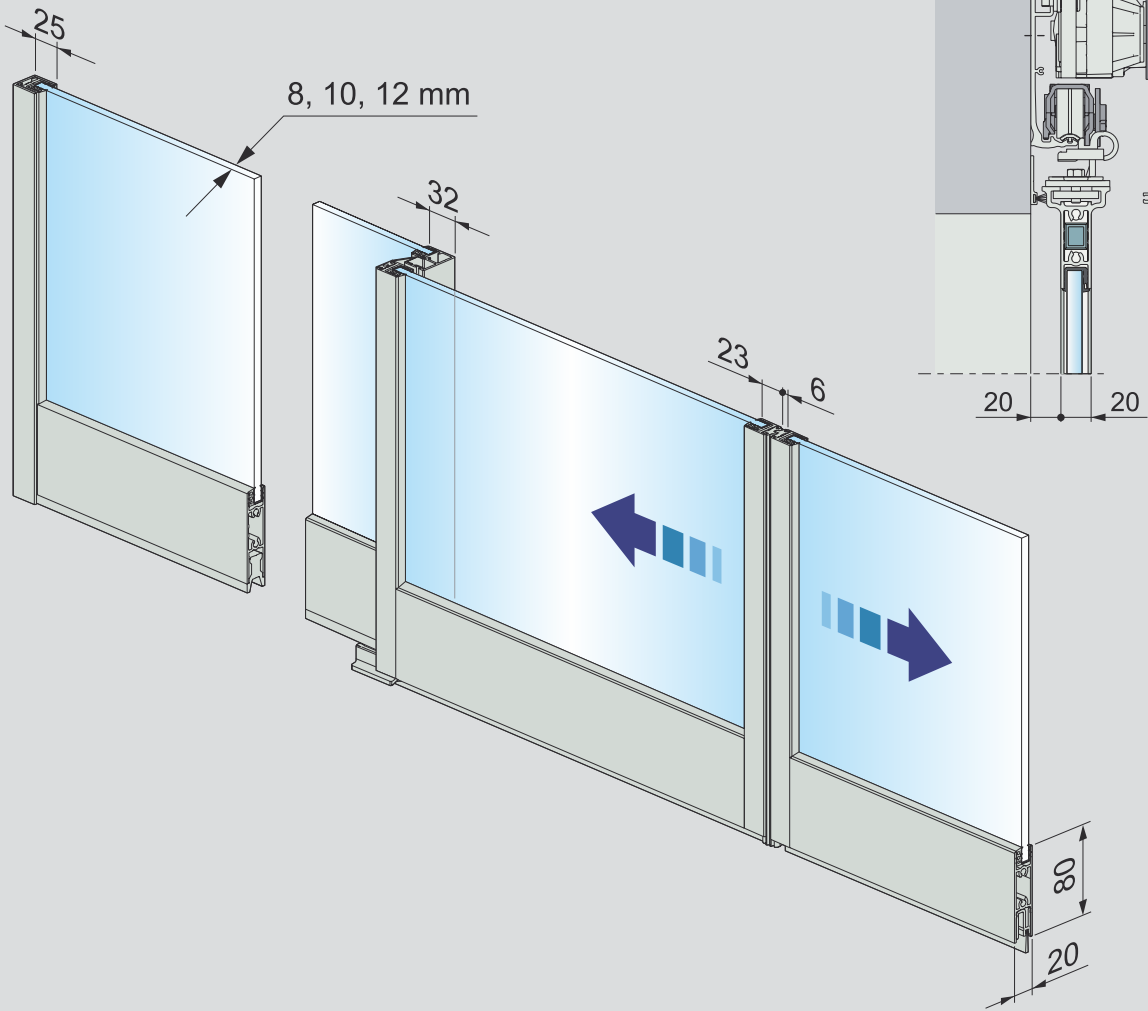

Wall mounted, only doors

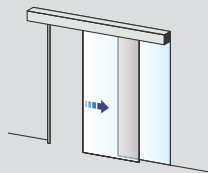
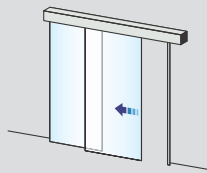
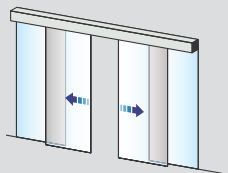

Wall mounted, doors and side screens

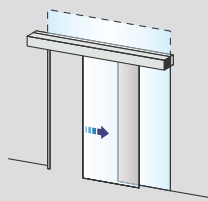
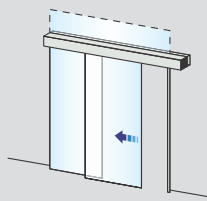
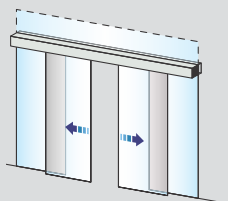

Beam mounted, doors and side screens
(option overlight)

ASSA ABLOY Slim Eco

ASSA ABLOY SL500

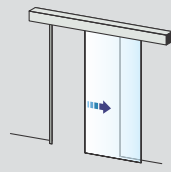
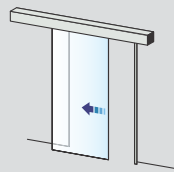
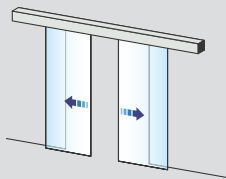
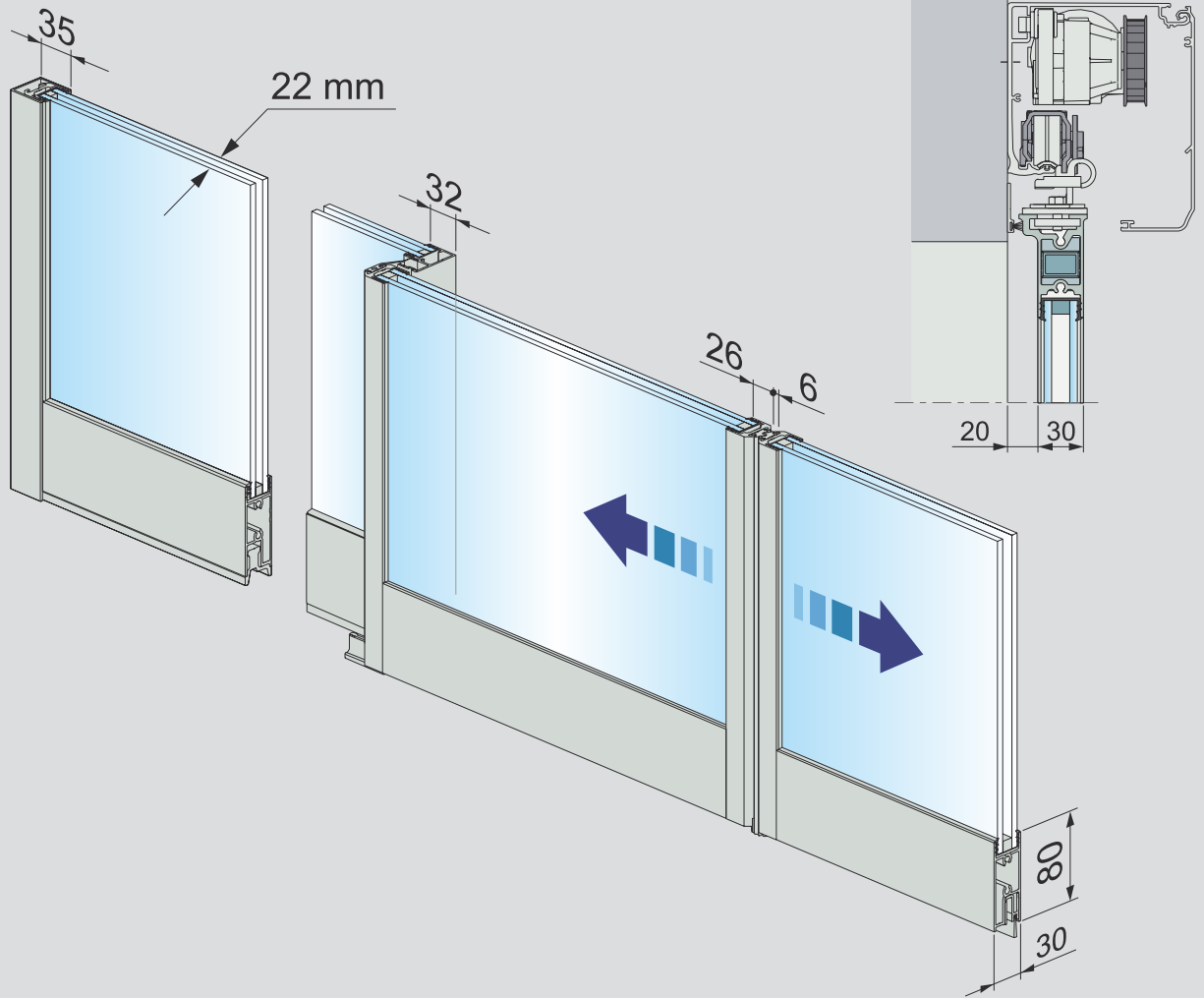

Wall mounted, only doors

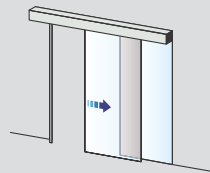
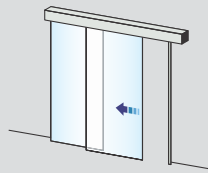
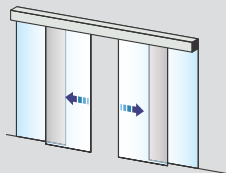

Wall mounted, doors and side screens

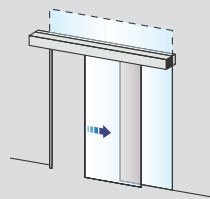
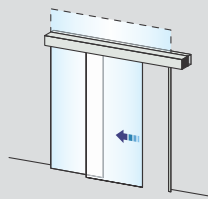
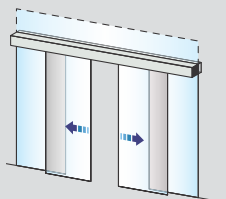

Beam mounted, doors and side screens
(option overhead)

ASSA ABLOY Slim Break-Out

ASSA ABLOY SL500

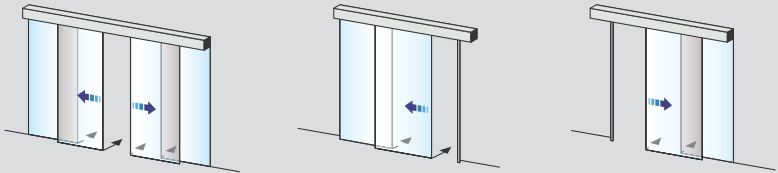
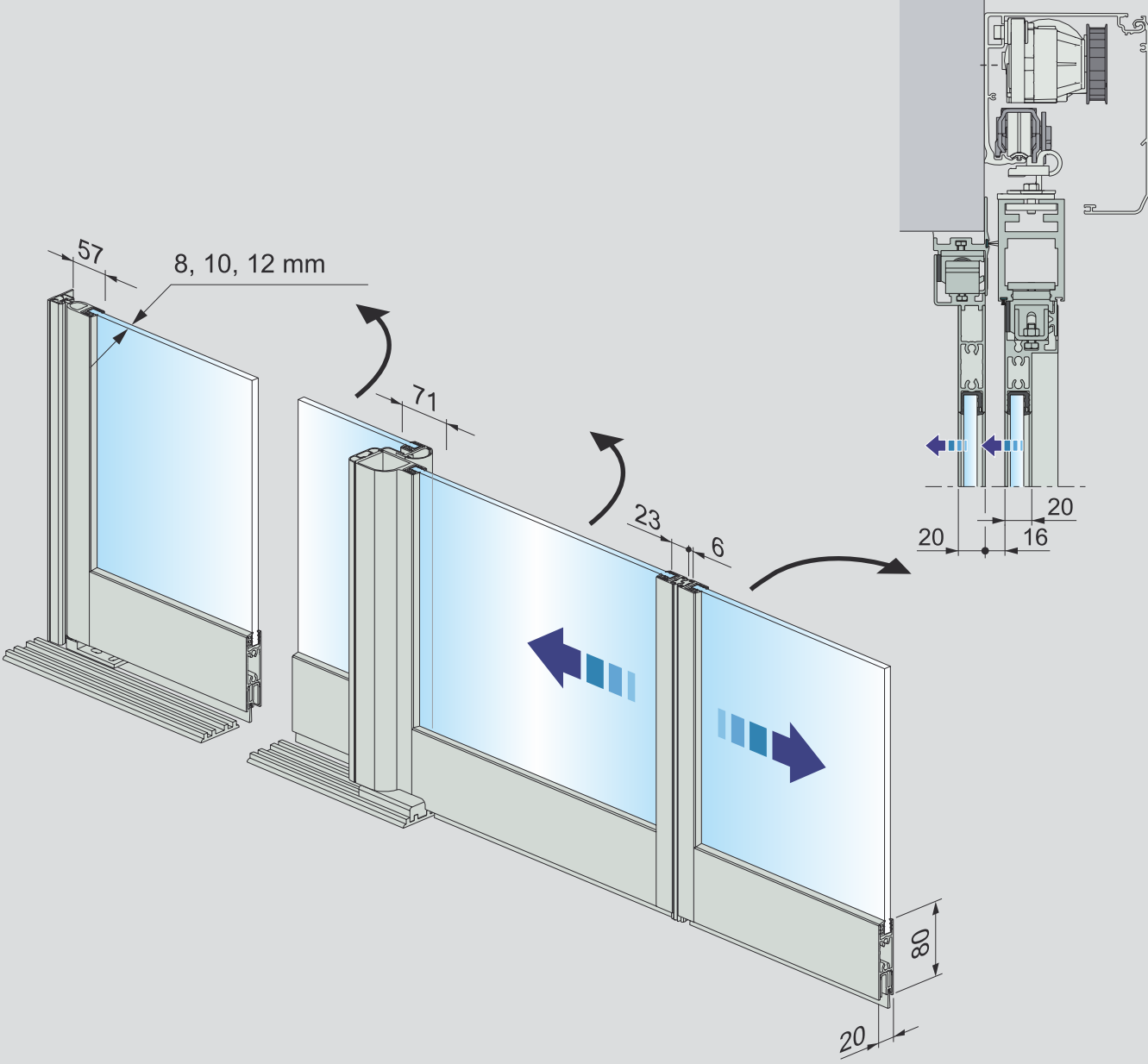

Wall mounted, doors and side screens

ASSA ABLOY Slim Reverse Break-Out

ASSA ABLOY SL500

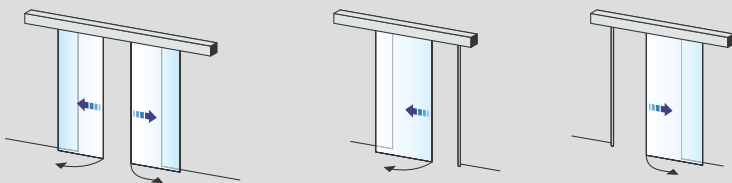
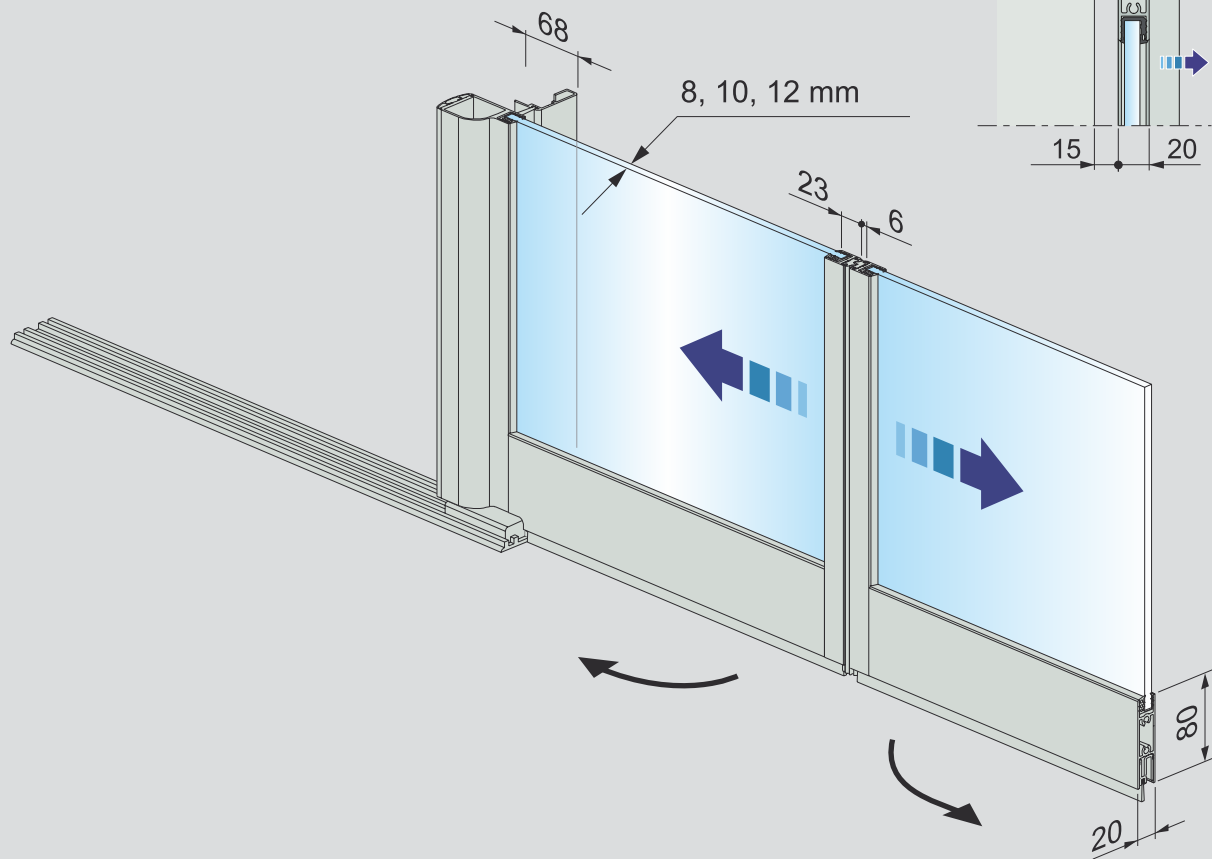

Wall mounted, only doors

Automatic sliding door system

ASSA ABLOY Frame

ASSA ABLOY
Entrance Systems

Experience a safer
and more open world



Accessories and Options

Profile type:
- Frame

Profile finish:
- anodized aluminium, colour on request

Glass type:
- 8 or 10 mm laminated (Frame only)
- 8 or 10 mm tempered (Frame only)
- 22 mm insulated glass

Glass finish: clear

Overlight (beam mounted only)

Side screens

Mechanical lock

The ASSA ABLOY Frame series includes:

- ASSA ABLOY Frame
- ASSA ABLOY Frame Break-Out
- ASSA ABLOY Frame Reverse Break-Out

ASSA ABLOY Frame

Its rugged design makes it particularly suitable for high-traffic entrances. The system consists of doors, operator, safety units and, if required, side screens and overlights. Available for beam- or wall mounting and supplied as bi-parting and single-sliding, all models can be tailored to individual customer requirements.

ASSA ABLOY Frame Break-Out & ASSA ABLOY Frame Reverse Break-Out

Break-out enables the doors and side screens to swing outward in an emergency, allowing exit through the entire door and side-screen space.

Reverse break-out performs the same way with the doors swinging inward. Especially suitable for indoor applications.

Safety features

An integrated activation and presence detection system enhances safety for users by detecting people or objects in the doorway, preventing the door from closing until it is safe to do so.

Sustainability

ASSA ABLOY's automatic door systems can reduce the amount of energy needed to heat or cool a building, resulting in lower costs and a smaller carbon footprint for customers. The ASSA ABLOY Frame series can be fitted with optional 22 and 40 mm thermo glass, thermally broken profiles, extra tight-fitting brushes and additional sensors for fine-tuning opening and closing times, further enhancing its energy-saving capabilities. Regular maintenance helps insure top performance and extends the life of the equipment, reducing its impact on the environment.

ASSA ABLOY Frame

ASSA ABLOY SL500

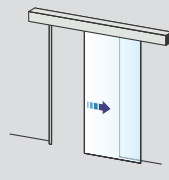
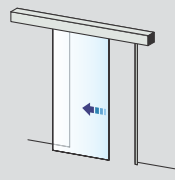
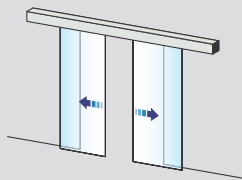
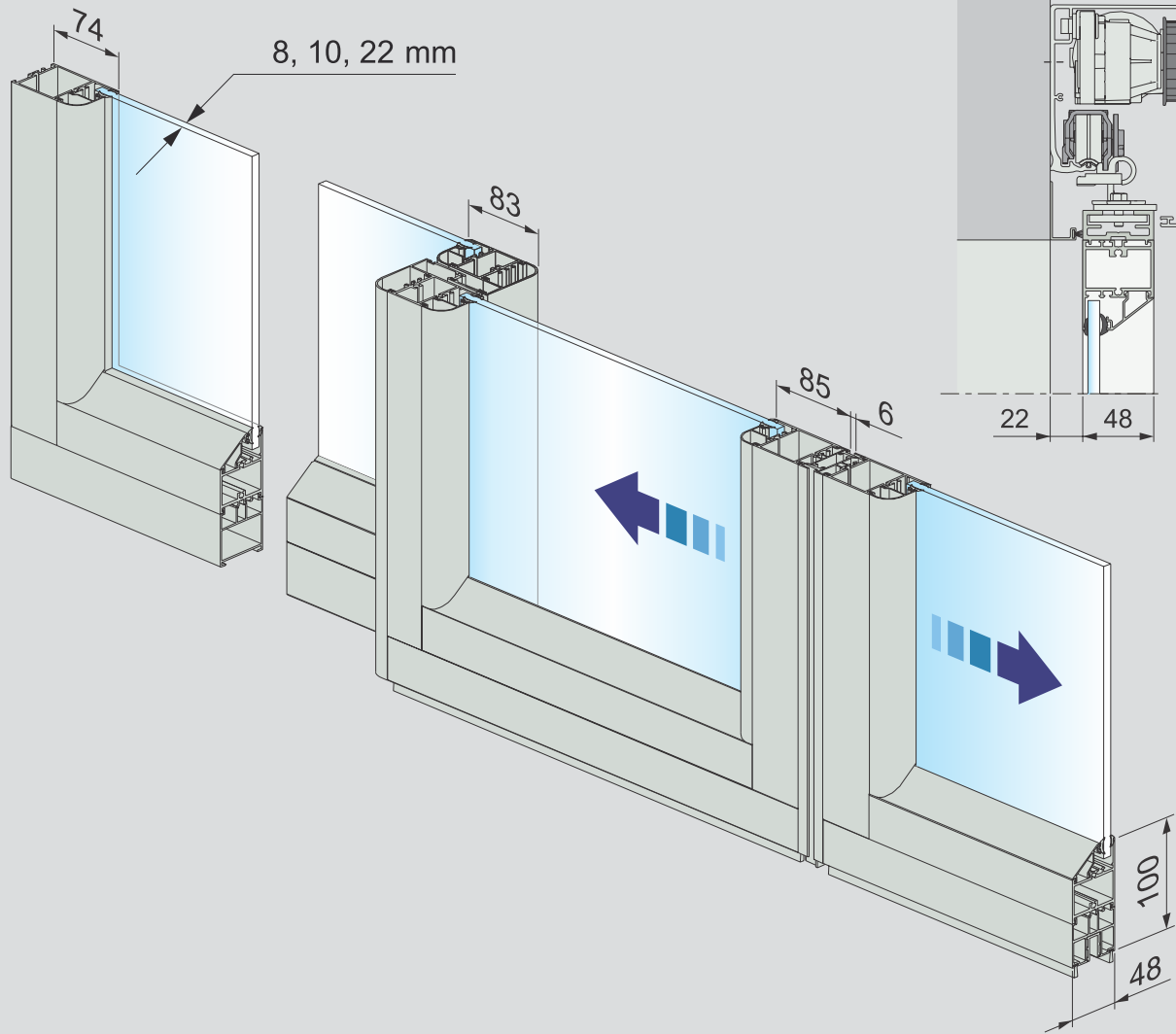

Wall mounted, only doors

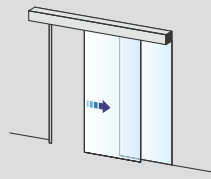
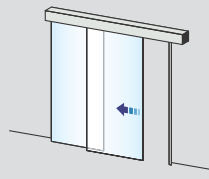
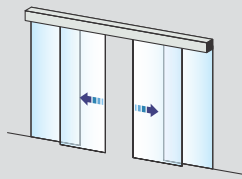

Wall mounted, doors and side screens

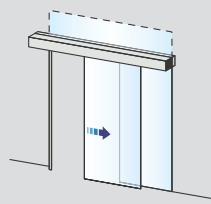
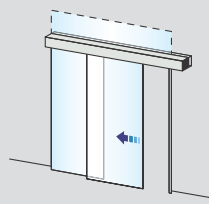
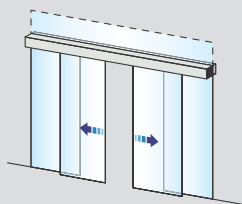

Beam mounted, doors and side screens (option overhead)

ASSA ABLOY Frame Break-Out

ASSA ABLOY SL500

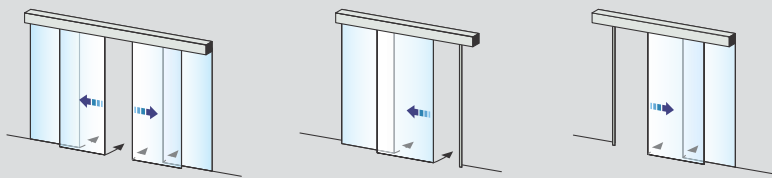
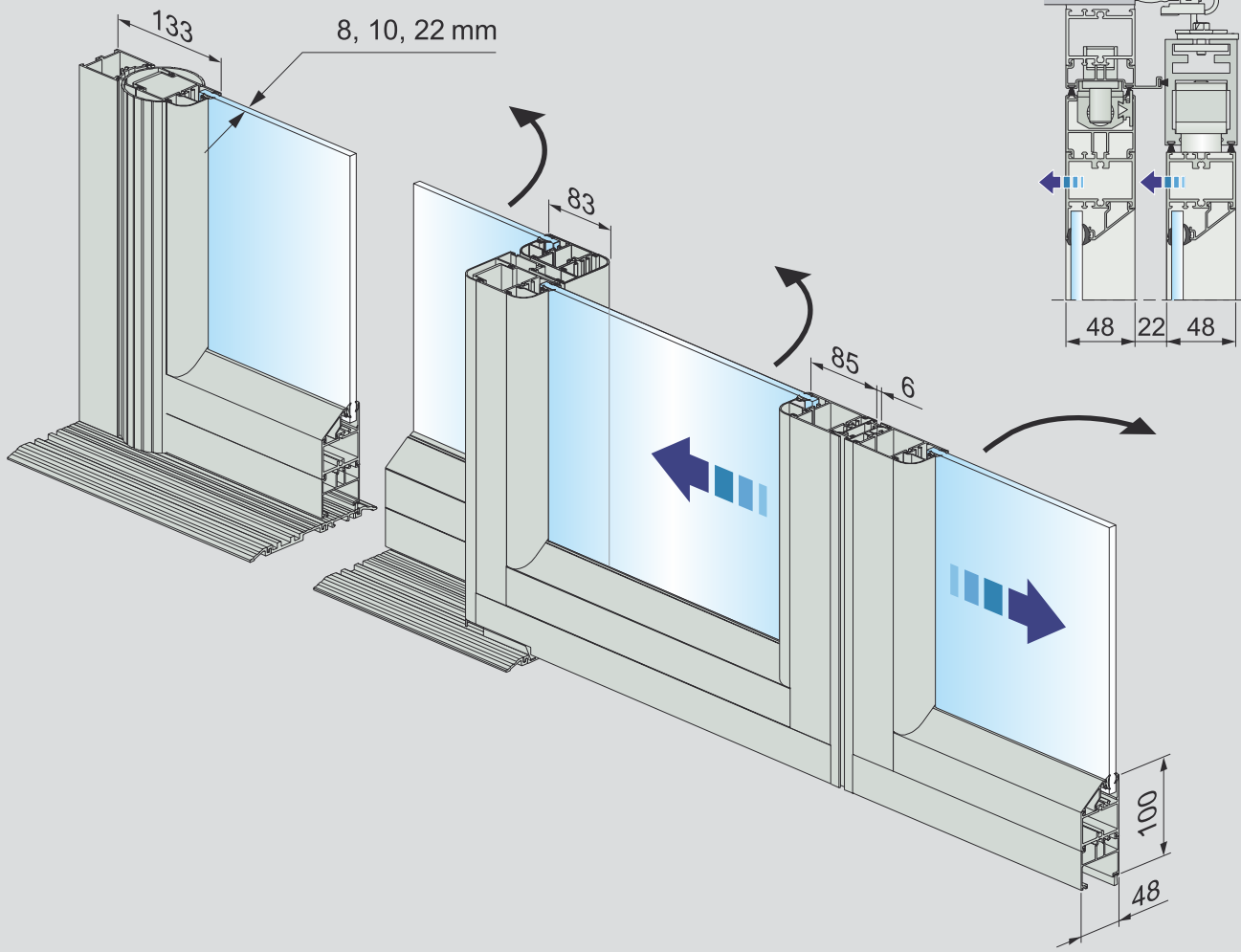

Wall mounted, doors and side screens

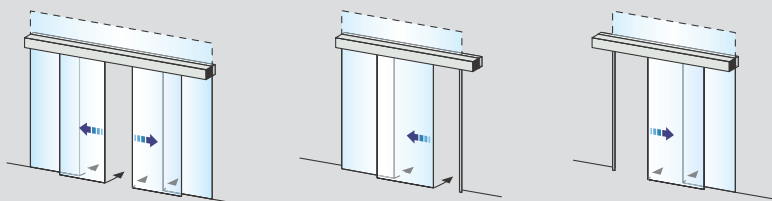

Beam mounted, doors and side screens
(option overhead)

Swing Door Operator

ASSA ABLOY SW110 Standard

ASSA ABLOY
Entrance Systems

Experience a safer
and more open world



A universal swing door operator that is quiet and energy efficient

Safe, secure and highly adaptable

The ASSA ABLOY SW110 Standard is an electro-mechanical swing door operator that relies on an innovative “push-and-pull” arm system to create safe passage for anyone, and anything.

Made to blend into any environment, and due to its low-noise operation, the SW110 is ideal for every kind of setting: from healthcare facilities to airports, offices, residential buildings and busy public areas.

Furthermore, the ASSA ABLOY SW110 Standard swing door operator is fully compliant with European standards and fire approved, making it ideal for creating and maintaining security, smoke and fire zones.

Silent and smart

Operated by a smart low-noise drive technology, the ASSA ABLOY SW110 Standard ensures extra silent opening and closing of the door. For a more reliable performance from an operator that will experience fewer breakdowns and require less maintenance. The SW110 also comes with a host of additional features and can be adapted to meet local and national regulations.

Technical data

Drive Dimensions	
Length	600 mm
Height	87 mm
Depth	124 mm
Door closer size	EN4 – EN6
Recommended max. door weight and door width Inertia J	Door Weight x (door width) ² /3 PUSH = 65 kgm ² , PULL = 65 kgm ²
Power supply	230 VAC, 50/60 Hz
Power consumption	67 W
Auxiliary voltage	24 V DC, 1000 mA
Opening angle	70° – 115°
Hold-open time	3 – 20 s / 5 – 20 s
Ambient temperature	-15° C to +50° C
Relative humidity (non-condensing)	up to 85% rel. humidity, non-condensing
Type of protection	IP20
Arm systems	Standard arm push and sliding arm pull
Noise emission	Less than 45 dB

Explore what makes ASSA ABLOY SW110 Standard stand out:

- Quiet, low-friction opening and closing technology
- Full flexibility in selecting Full Power or Low Energy operating modes
- Suitable for single and bi-parting doors with lintel or door leaf installation
- Easy to maintain and service
- Same installation set-up as our other operators, making upgrades a streamlined procedure
- Available with drive system to support different door applications
- Platform-based, coherent approach
- The sensors can be easily installed and put into operation
- The operator is encased in an elegant aluminum cover
- Delivered as an assembly kit for easy on-site installation

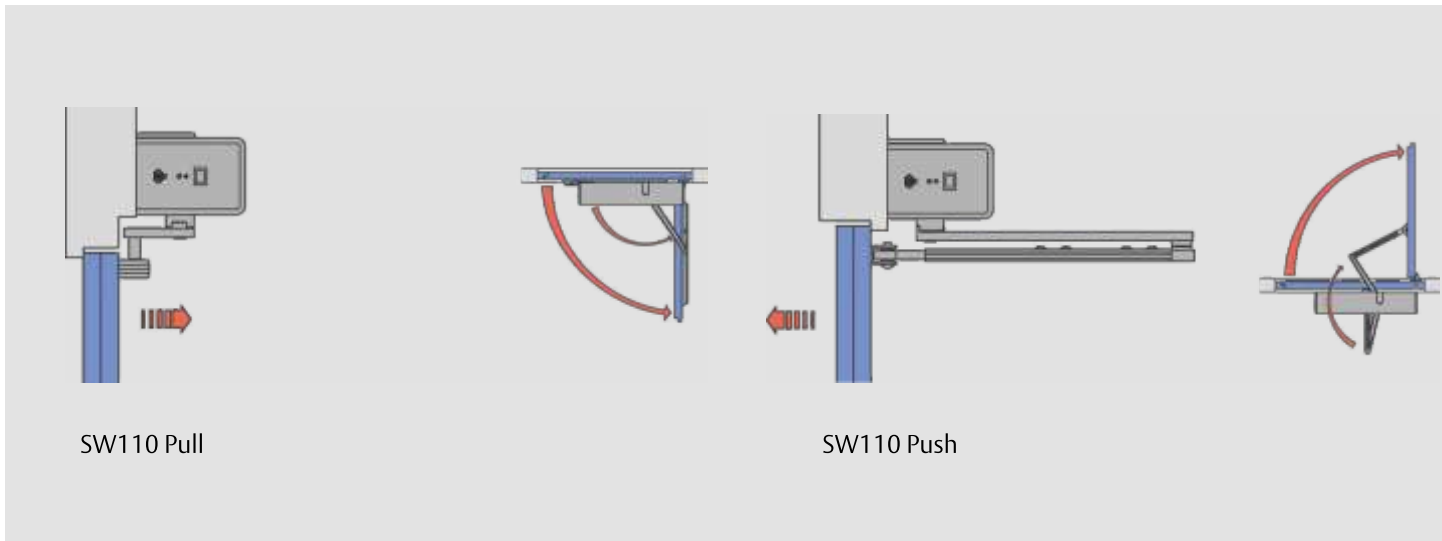

SW110 Pull

SW110 Push

Full power or low energy operating mode

The powerful operator installed in the ASSA ABLOY SW110 Standard is universally applicable, able to handle large and heavy doors without the installation of additional upgrade modules. Requiring few to no sensors, it can be set to different modes to adjust settings such as opening speed and kinetic energy.

Designed to fit any requirement

- **Single door operator:** one drive unit and one control unit fitted under cover
- **Double door operator:** two door operators available with different options, such as modular
- **Performance:** able to move high-weight doors of up to 300 kg
- Program door speed to meet your needs (from 3 to 20 s to open and 5 to 20 s to close)
- Program time doorway remains fully open (from 0 to 60 s)

Functional on any level

“**Push and go**” makes the door open automatically from closed position if manually pushed.

PUSH (standard push arm system) - The operator is installed on the wall on the opposite side as the door swing with a door opening angle adjustable to 115°

PULL (sliding arm system) – The operator is installed on the wall on the same side as the door swing with a door opening angle adjustable to 115°

LEVER ADAPTERS – Allow the operator to be fitted higher on the wall or the arm lower on the door leaf.

POWER ASSIST – Heavy doors can be opened manually with minimum effort.

Accessories and options

Extension unit FEM1 – Used if additional functions are required, e.g. interlock system, configurable input- and output signals

Finger trap protection devices

Manual and automatic activation units

Impulse and presence detection sensors

Program selectors, electronic or key-operated

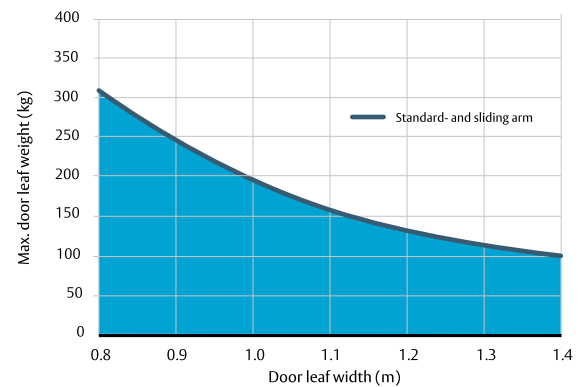

Recommended door leaf width for door closer classes



This equipment should be installed, regularly inspected, maintained and serviced by trained and authorized personnel. Preventive maintenance plans are highly recommended for a proper and safe operation. Talk to your ASSA ABLOY Entrance Systems representative to learn more about our service offering

Swing Door Operator
ASSA ABLOY SW60

ASSA ABLOY
Entrance Systems

Experience a safer
and more open world

Introducing
the new reality in doors.



SW60
THE GAME CHANGER

In the new reality,
you swipe the
door open

Touching doors should be a thing of the past. And with our state-of-the-art smart control app, you can open the door right from your phone.



The ASSA ABLOY SW60 has a range of options, controls and assistance

Setup assist

Our apps walk you through the process from install to operation.

Door control

Open, close and lock doors at the push of a button.

Custom functions

Personalize the ASSA ABLOY SW60 with customizable settings and preferences.



the SW60

Technical specs

47 mm height
Manual push: 2.2 – 6.8 kg

Max weight: 160 kg
Max width 1,230 mm

Arms options



Standard push arm
(surface mounted)

Sliding pull arm
(surface mounted)



Sliding push arm
(surface mounted)

Concealed arm
- push/pull
(concealed mounted)

SMALL IN DESIGN, BUT MIGHTY IN PERFORMANCE

Touch free



- Touchless Switch compatible
- Limits contact with germs
- Perfectly fitted for restrooms, office, medical units, meeting rooms, and assisted living facilities the door can be easily opened without physical contact

Smart access



- Expedites setup process
- Door functions controlled by app
- Available in the Apple App store and Google Play Store

Sleek in it's design



- Perfect for limited overhead space
- Blends in with your door frame
- Push or pull configuration
- Available in clear silver color
- Winner of the Red Dot Award: Product Design 2021

Easier installation

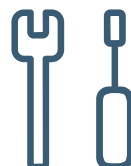

- Retrofit to existing manual doors
- Experience quick and easy installation in no time (under 1h)
- No electrician required for installation
- Mobile app for installation walkthrough

Essential service and beyond

Regular maintenance is essential to ensure the doors functioning at the highest level in accordance with safety regulations. Maintenance is not carried out automatically during the warranty period and it is recommended that customers sign a maintenance agreement within six months of installation to provide peace of mind and help reduce operating and maintenance costs over the life of the product.

The ASSA ABLOY sliding doors are manufactured to the highest quality standards and if maintained correctly will last decades, providing trouble free secure access to sensitive and vulnerable areas.

Our service technicians are available to respond to any queries. In the event of a malfunction of your automatic door, our schedulers will immediately organise an appointment with a nearby service technician. Our intuitive service app can be installed on tablets and mobile devices to support technician during service and maintenance work. With a user-friendly interface and downloadable updates, the app facilitates rapid troubleshooting, and the help function allows users to request remote support if required.



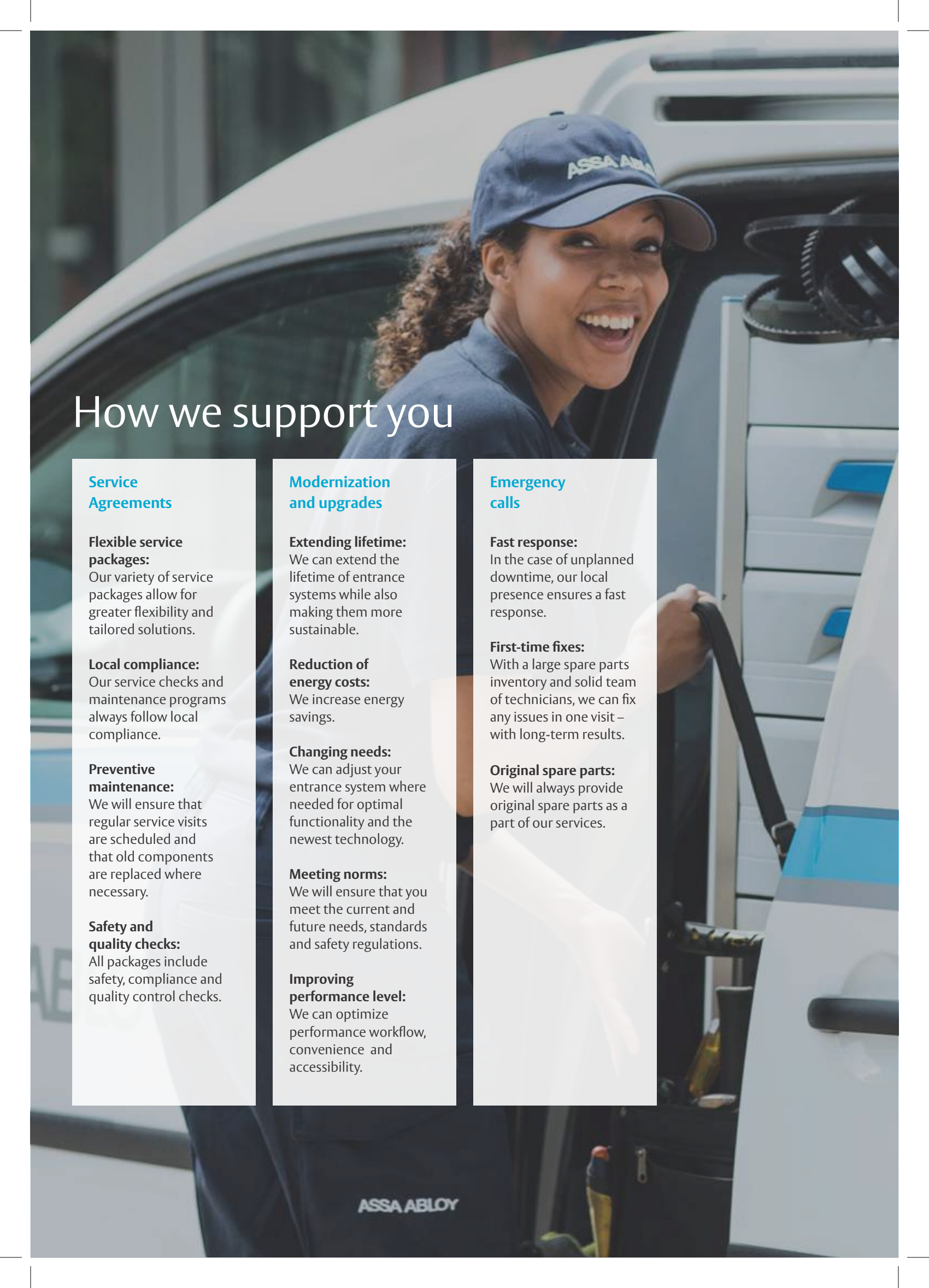

How we support you

Service Agreements

Flexible service packages:

Our variety of service packages allow for greater flexibility and tailored solutions.

Local compliance:

Our service checks and maintenance programs always follow local compliance.

Preventive maintenance:

We will ensure that regular service visits are scheduled and that old components are replaced where necessary.

Safety and quality checks:

All packages include safety, compliance and quality control checks.

Modernization and upgrades

Extending lifetime:

We can extend the lifetime of entrance systems while also making them more sustainable.

Reduction of energy costs:

We increase energy savings.

Changing needs:

We can adjust your entrance system where needed for optimal functionality and the newest technology.

Meeting norms:

We will ensure that you meet the current and future needs, standards and safety regulations.

Improving performance level:

We can optimize performance workflow, convenience and accessibility.

Emergency calls

Fast response:

In the case of unplanned downtime, our local presence ensures a fast response.

First-time fixes:

With a large spare parts inventory and solid team of technicians, we can fix any issues in one visit – with long-term results.

Original spare parts:

We will always provide original spare parts as a part of our services.

The ASSA ABLOY Group is the global leader in access solutions.
Every day, we help billions of people to experience a more open world.

ASSA ABLOY
Entrance Systems

ASSA ABLOY Entrance Systems provides solutions for efficient and safe flow of goods and people. Our offering includes a wide range of automated pedestrian, industrial and residential doors, loading dock equipment, perimeter fencing and service.

ASSA ABLOY

Entrance Systems

DELHI-NCR:

8-A, Udyog Vihar, Part I & II, Greater Noida (U.P.)-201306
T: +91-120-4751000

BANGALORE:

716/966/2, 9th Main Road, 7th Sector, H.S.R Layout,
(Near B.D.A. Complex) Bangalore - 560102
M: 9535 6771 18

MUMBAI:

Office No.507, Thacker Tower Premises, Co-operative Society Ltd.,
Plot No.86, Sector 17, Vashi, Navi Mumbai - 400705
M: 9535 6771 17

KOLKATA:

Sri Manjari Building
4th floor, 1/1 Camac street, Kolkata - 700071
M: 9674644490

Email:

info.in.entrance@assaabloy.com

Website:

www.assaabloyentrance.com/in

Follow us:



Please enter ASSA ABLOY Entrance
in the channel's search field.